



INTEGRATED SOLUTIONS FOR POTATO PROCESSING



SHANDONG SENSITAR INDUSTRIAL EQUIPMENT CO.,LTD



COMPANY PROFILE

Shandong Sensitar Industrial Equipment Co.,Ltd is located in Weifang, Shandong Province, specializing in integrated solutions for potato processing. The company's manufacturing base has a modern factory of 100000 square meters, with various advanced processing equipment.

We focus on technology and innovation continuously introducing production technologies and processes from EU and USA. Our company has independently developed integrated solutions and various core equipment for French fry lines, potato chip lines, potato flake lines, and potato harsh brown lines. Its products are exported to Europe, America, Central Asia, and the Middle East. We are willing to sincerely cooperate with you to achieve great success in future.



OUR CUSTOMERS



SHANDONG SENSITAR INDUSTRIAL EQUIPMENT CO.,LTD

Tel:008613562623486
Email: hifeng@xzdjx.com
Add: No.8633 Mizhou East Road, Zhucheng City, Weifang city, Shandong Province.

Sales agent in India: First Technodrives Engineering Solutions & Services
Add: _268/A, Onnam Mile, AM Road, Perumbavoor-683542, Kerala (Country:India)
Contact : Anup Ipe Jacob
Tel: 00919562065776
Email: firsttechnodrives@gmail.com

FRENCH FRIES LINE

Continuously producing high-quality French fries requires stable and reliable equipment systems, as well as the application of advanced technological processes. Our French Fries line is designed according to the European production process and flow, equipped with advanced Steam Peeler, Hydro Cutter, and Starch Collection Systems, and our equipment expanded to Europe, North America, Central Asia, Mid-east, North Africa and so on.

Model: 0.5T/h , 1T/h , 2T/h , 3T/h , 5T/h , 10T/h

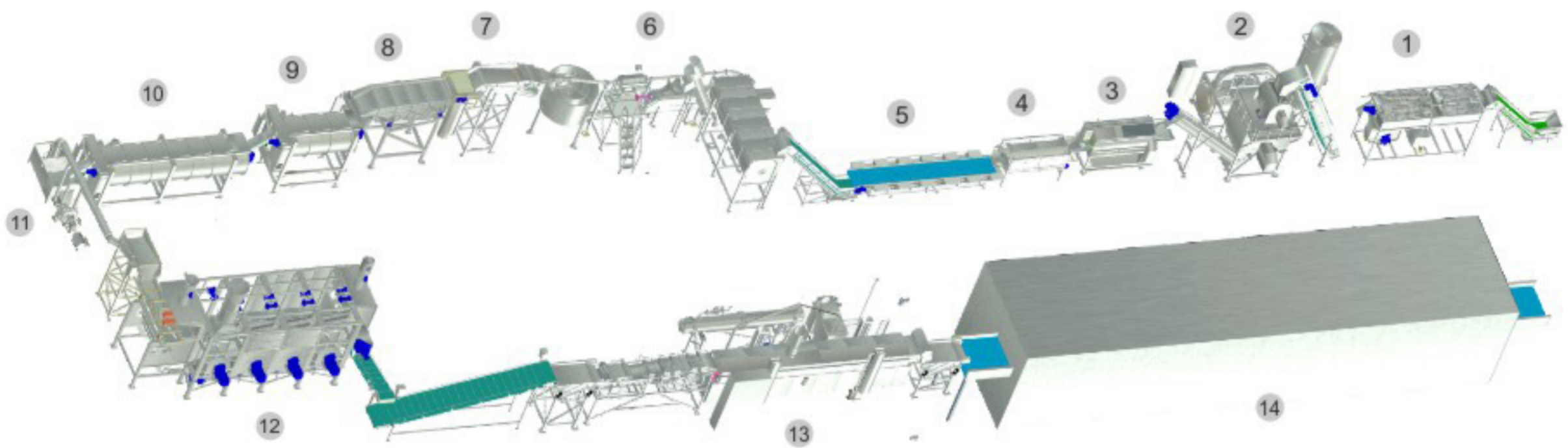

- | | | | | |
|-----------------------|-----------------|----------------------|-------------------|-----------------------|
| 1 Destoning & washing | 2 Steam peeling | 3 Brush cleaning | 4 Drum cleaning | 5 Inspection conveyor |
| 6 Hydro cutter | 7 Sliver sorter | 8 Short strip sorter | 9 First blanching | 10 Second blanching |
| 11 Additives system | 12 Dryer | 13 Fryer | 14 IOF freezer | |

◆ OUR PROJECTS



POTATO CHIPS LINE

Our mission is to provide consumers with delicious and crispy high quality fresh-cut potato chips. With years of research and application experience, Our company has provided perfect potato chips production lines for dozens of customers around the world. The production line is equipped with vertical grinders, centrifugal slicers, and a fryer specially for potato chips, putting out end products with balanced quality and consistent characteristics.

Model: 100kg/h , 300kg/h , 500kg/h , 1000kg/h



- 1 Destoning & washing 2 Abrasive peeler 3 Roll inspection table 4 Cutter 5 Rinsing
- 6 Drum blancher 7 Drying system 8 Frying 9 Fat separator 10 Optical sorter 11 Spice mixing

◆ OUR PROJECTS

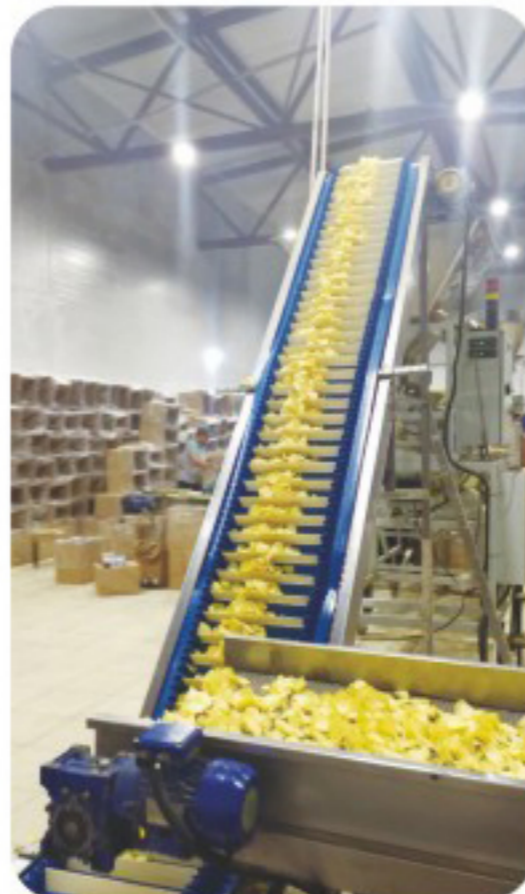

POTATO FLAKES LINE

The potato flakes line can be used to produce potato flakes and sweet potato flakes, which can be marketed as Instant Potato Mash, as well as food ingredients of formed potato chips and baked products. Our company's potato flakes line is designed and manufactured in accordance with European standards, equipped with steam peelers, hydro cutters, drum dryer, etc, with the characteristics of durability, high efficiency, and strong product consistency.

Model: 500kg/h, 800kg/h, 1000kg/h, 1600kg/h, 2000kg/h, 2400kg/h



- | | | | | |
|-----------------------|----------------|----------------|----------------------|----------------|
| 1 Destoning & washing | 2 Steam peeler | 3 Brush washer | 4 Inpection conveyor | 5 Hydro cutter |
| 6 Blancher | 7 Cooler | 8 Cooker | 9 Puree machine | 10 Drum dryer |

◆ OUR PROJECTS



STEAM PEELER

The steam peeler consists of a elevator, weighing hopper, peeling tank, expansion tank, frame, steam system, electronic control system, etc. It is the fastest and most efficient equipment for peeling tubers, certain fruits and vegetables. Compared with traditional peeling methods that result in a loss of over 20%, steam peelers can reduce peeling loss to 4-7%, to promote production yield significantly.

Model: 2-5tons/h,6-10tons/h,10-15 tons/h



◆ OUR PROJECTS



HYDRO CUTTER

The hydro cutter consists of a feeding pump, feeding pipelines, and a cutting block, which can cut materials into strips, slices, wedges, or other possible shapes. It has the characteristics of fast cutting speed, low material loss, easy switching of cutting blocks, flexible assembly in a line, and long-distance transportation while soaking and cleaning materials in the pipes.

Model: 3tons/h,6tons/h,10tons/h



◆ OUR PROJECTS



AUGER BLANCHER

The Auger Blancher can be used in the line of French fries, potato chips, potato flakes, as well as other vegetables and fruit. Auger Blancher is equipped with an external heat exchanger and a balanced heating system, providing uniform and rapid heating with low noise; The material is discharged with the Ferris wheel at a high position without any retention; The gap between the spiral blade and the cylinder is less than 4mm, and will not damage the material.

Model: B1300 , B1600

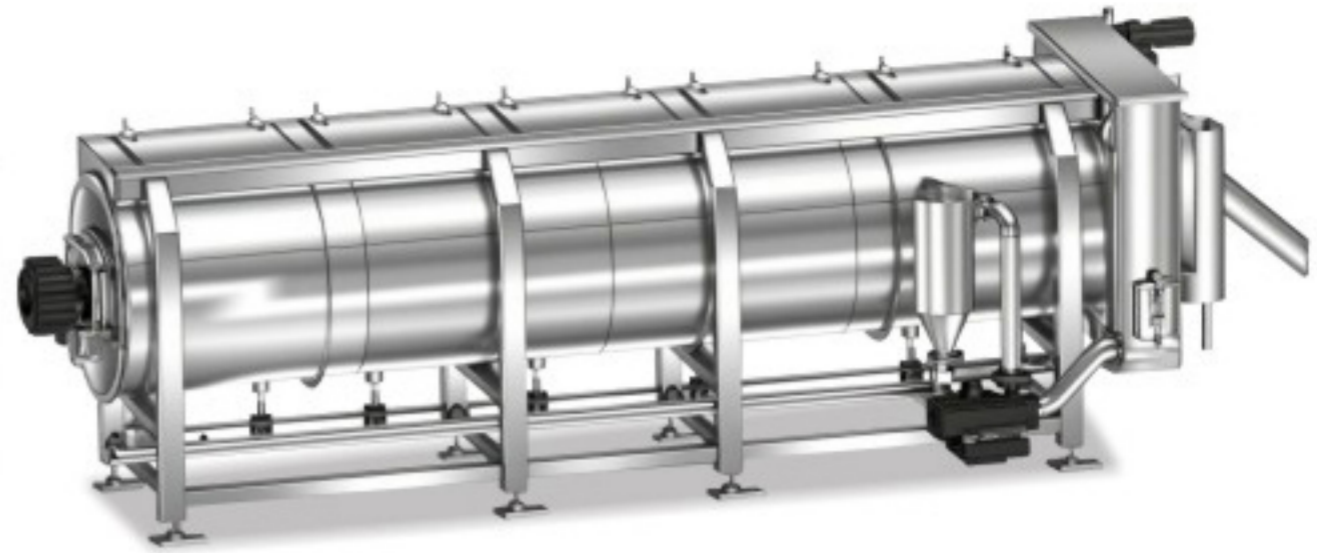

BELT DRYER

Belt dryer is mainly used for drying and equilibrating potato fries, fruits and vegetables, etc., removing excess moisture while allowing the moisture to be evenly distributed within the foodstuff, resulting in a good taste and texture. Belt dryer adopts a multi-zone design with independent temperature and humidity control for each zone which operates independently with high air volume and high-intensity circulating air, and is equipped with high-efficiency.

Model: AD1000 , AD1800, AD2500

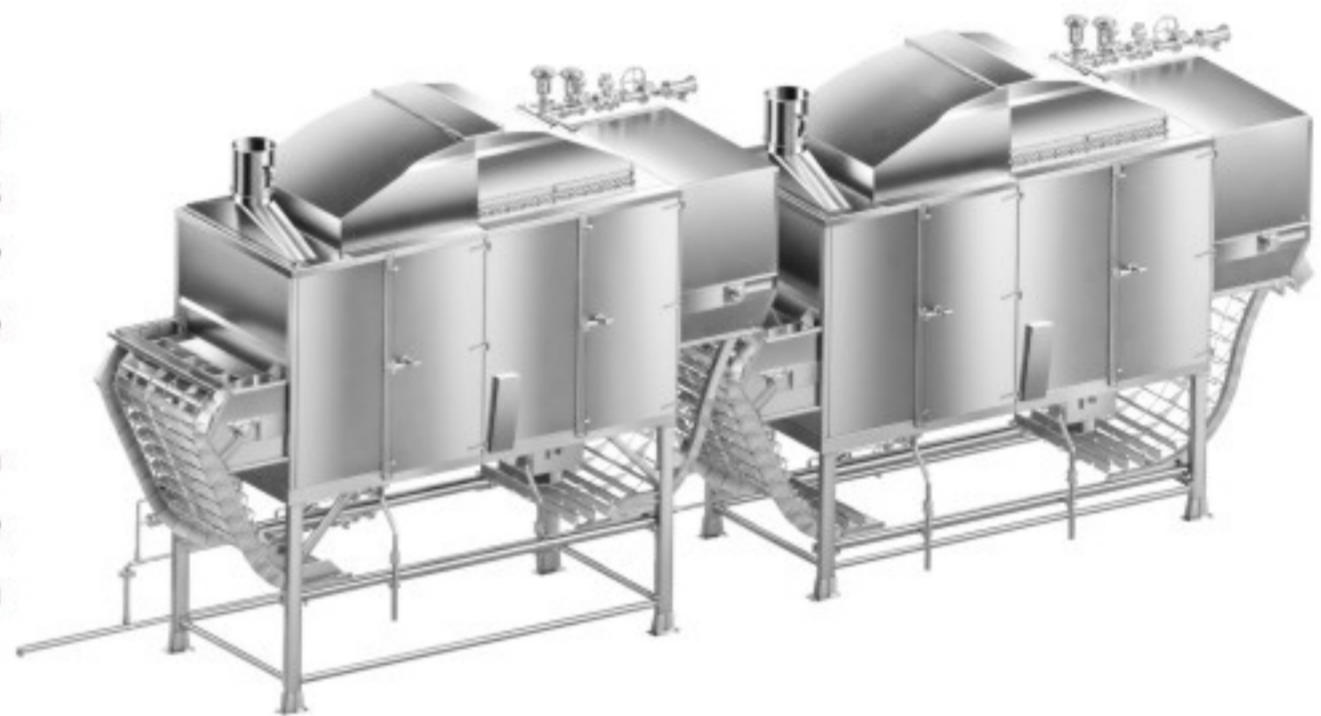

BELT FRYER

Our company has developed various fryers to meet customers' specific demands for French fry fryers, potato chips, and prepared food, all of which use infrared sensors to automatically control the liquid level and are equipped with a three-stage oil filtration system for efficient oil purification. The company is the first in China to launch steam heated fryer, which uses steam instead of thermal oil for heating, avoiding the risk of thermal oil leakage and contaminating products, and saving customers investment cost of an extra thermal oil boiler.

◆ MODEL

French Fries Series: 0.5T/h , 1T/h , 2T/h , 3T/h , 5T/h , 10T/h;
 Potato Chips Series: 100kg/h , 300kg/h , 500kg/h, 1000kg/h;
 Prepare Products Series: 0.5T/h , 1T/h , 2T/h , 3T/h , 5T/h , 10T/h

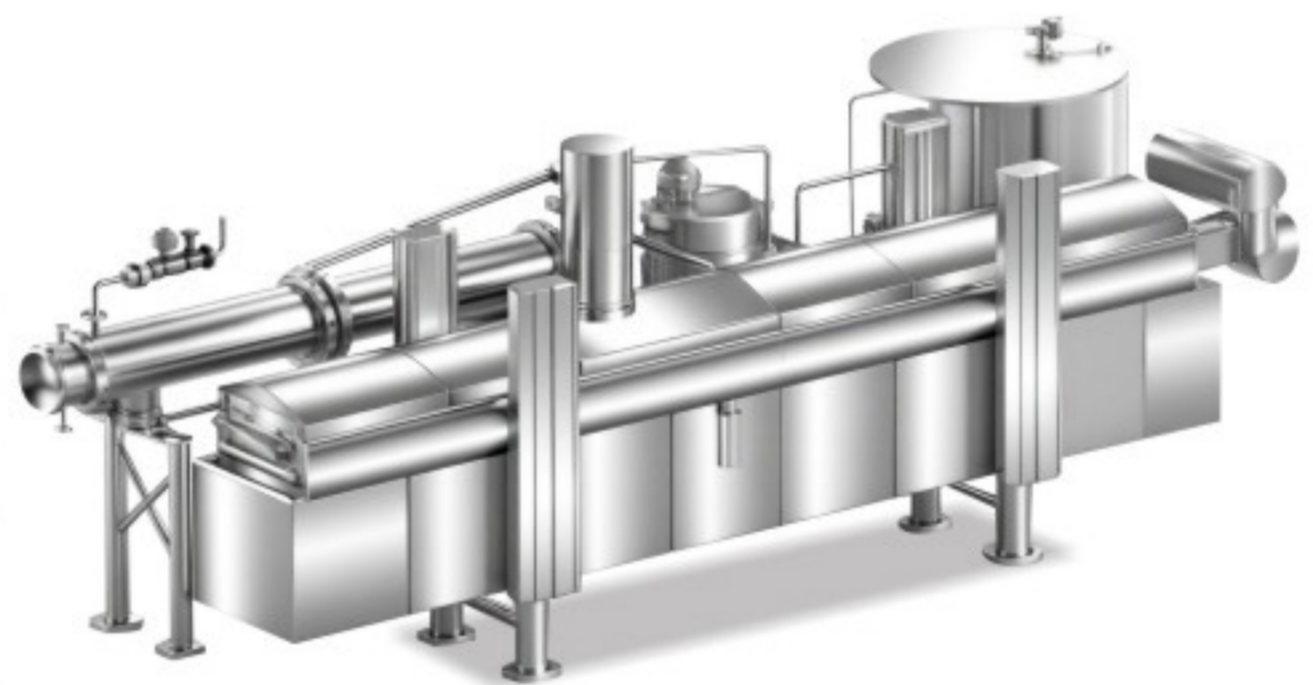

Belt filter



Paper filter

DRUM DRYER

Drum dryer is the core equipment in the potato flakes line, which continuously dries the material on the surface of the drum through internal heat conduction. The dried material is scraped out by a scraper installed on the surface of the drum. Drum dryer can make mashed potato even application, with same thickness and good consistency, resulting in less waste and greatly improving product quality and output.

Model: 500kg/h, 800kg/h

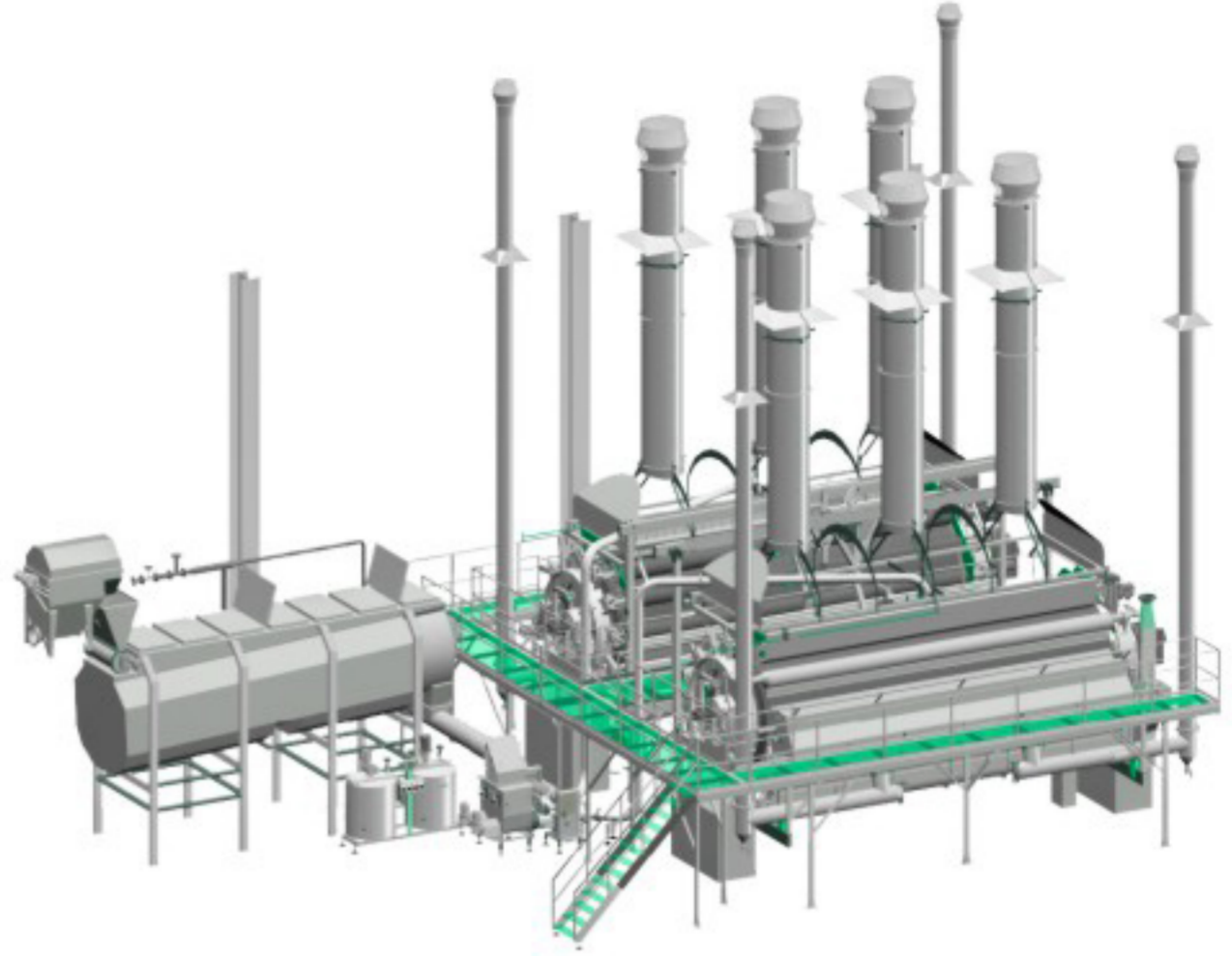

INDIVIDUAL QUICK FREEZING MACHINE

The IQF machine blows cold air from bottom to top through the material, moving it forward in a suspended state and allowing it to fully contact with the cold air, thereby achieving rapid freezing and avoiding material adhesion. The equipment consists of a refrigeration system, fans, conveyor belts, and control system, suitable for quick freezing process of French fries, fruits and vegetables.

Model: F1000, F3000, F5000



STARCH COLLECTION SYSTEM

The starch collection system is designed for separation and collection of the free starch generated in the production of French fries, potato chips, and potato flakes, maximizing our customers' benefits while reducing their environmental cost. The equipment consists of potato residue separator, cyclone, vacuum drum, collector, circulation system. It operates automatically to collect high purity starch.

